



DP

MULTIFUNCTIONAL TANKS WITH FIXED BUTYL DIAPHRAGM AND INSULATED PROTECTIVE SHEATH

(5 - 500 LITRI)



DP 5 - 35

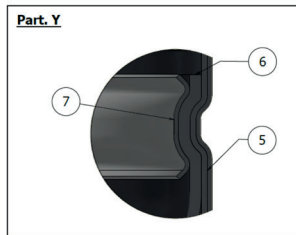
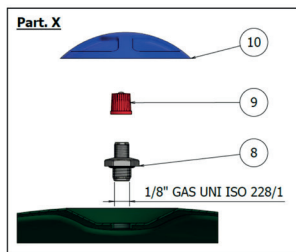
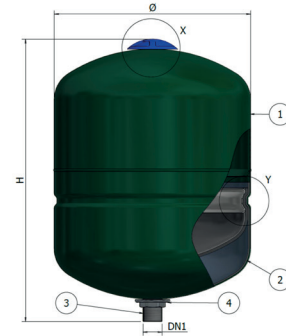

DPV 50 - 500

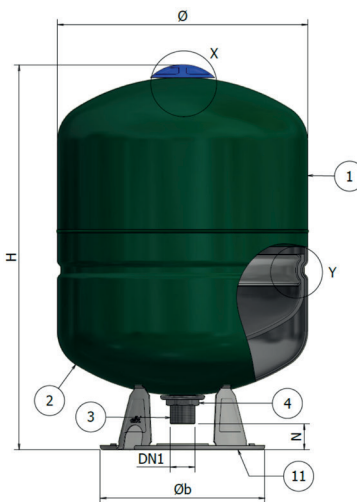

DPH 18 - 60

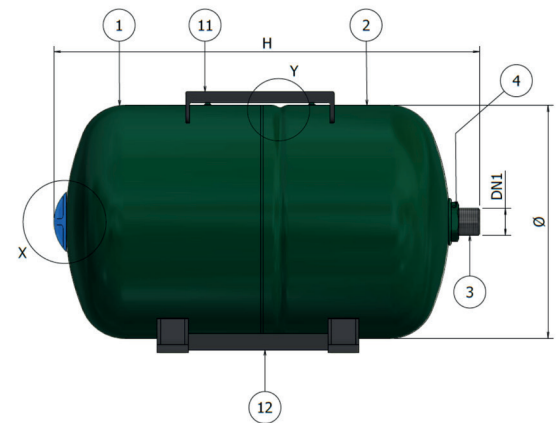

CE certified product



For air conditioning systems



For drinking water



For pressurisation systems



For sanitary hot water



Water hammer arrester



For heating systems

Multifunctional tanks with fixed-bladder and protective sheath

Multifunctional sanitary vessels with fixed bladder are designed to be fitted both as expansion tanks into sanitary systems, suitable to absorb the water expansion volume generated by a changing temperature, as well as pressure tanks for cold water sanitary systems.

Both applications are possible thanks to the protective sheath with patented crimping system that ensures the protection against corrosion of the inner surface of the tank.

In your Domestic Hot Water system install Elbi expansion tanks in the cold water supply pipe (do not install in the hot water drawoff pipe).

Characteristics:

- Min./max. working temperature: -10° / +99°C
- Max working pressure: 10 bar
- Pre-charge pressure: 2,5 bar
- Hydrostatic test pressure: 14,3 bar
- Fixed alimentary diaphragm in butyl
- Alimentary protective sheath in butyl
- Stainless steel connection with hexagonal nut
- Double metallic crimp
- Long lasting epoxy powder paint, green RAL 6005;

Reference standard:

- Declaration of conformity to essential safety requirements specified in 2014/68/UE Directive;

- CE approved

WARRANTY: 5 YEARS